



# AUD

## Wire Coil Pay-off

Expertise, Customer Driven, Service – in Good Hands with NIEHOFF



# AUD

## Design:

- loaded via fork lift truck

## Increase in productivity:

- continuous operation through welding of wire end to wire start
- automatic wire changeover from empty to full coil

## Energy and cost efficiency:

- wire tangle monitoring with automatic switch-off

## Technical data

type		AUD 1100	AUD 2000
individual wire dia.	Cu soft	mm 1.8 ... 3.6	3.6 ... 8.0
		AWG 14 ½ ... 11 ½	14 ½ ... 8
	Cu hard	mm 1.8 ... 3.6	
		AWG 14 ½ ... 11 ½	
max. pay-off speed		m/s 3	2.5
		fpm 590	490
number of pay-off positions		2	2
coil dimensions	max. outer dia.	mm 1,100	2,000
	max. height	mm 1,800	
	max. pallet dimensions	mm	2,000 x 2,000
machine dimensions (W x D x H)		m 1.14 x 2.25 x 3.60	
	Including safety fence	m	3.68 x 5.74 x 4.80

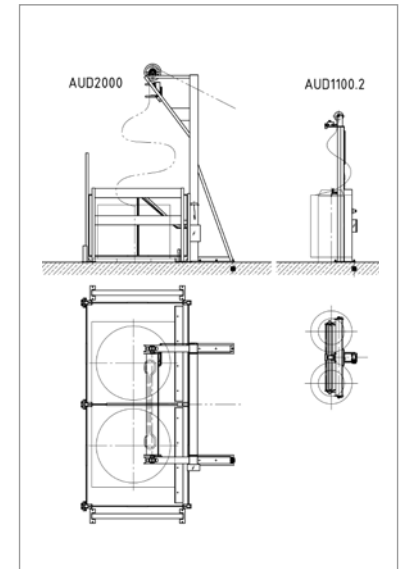

We reserve the right to modify technical specifications according to technical improvement and advances. 03.2018